



ORGANIZE IT ALL.

PLEASE READ INSTRUCTIONS COMPLETELY BEFORE ASSEMBLY

For assistance or missing parts in the USA, please email customerservice@kennedy-intl.com or call **Monday thru Friday (732) 654-2770**
All international (outside USA) customers who have missing, defective or damaged parts must contact the retailer directly to make an exchange or return for refund. All other customer service product and/or questions may be directed to us (in English).

Style:NH-34951

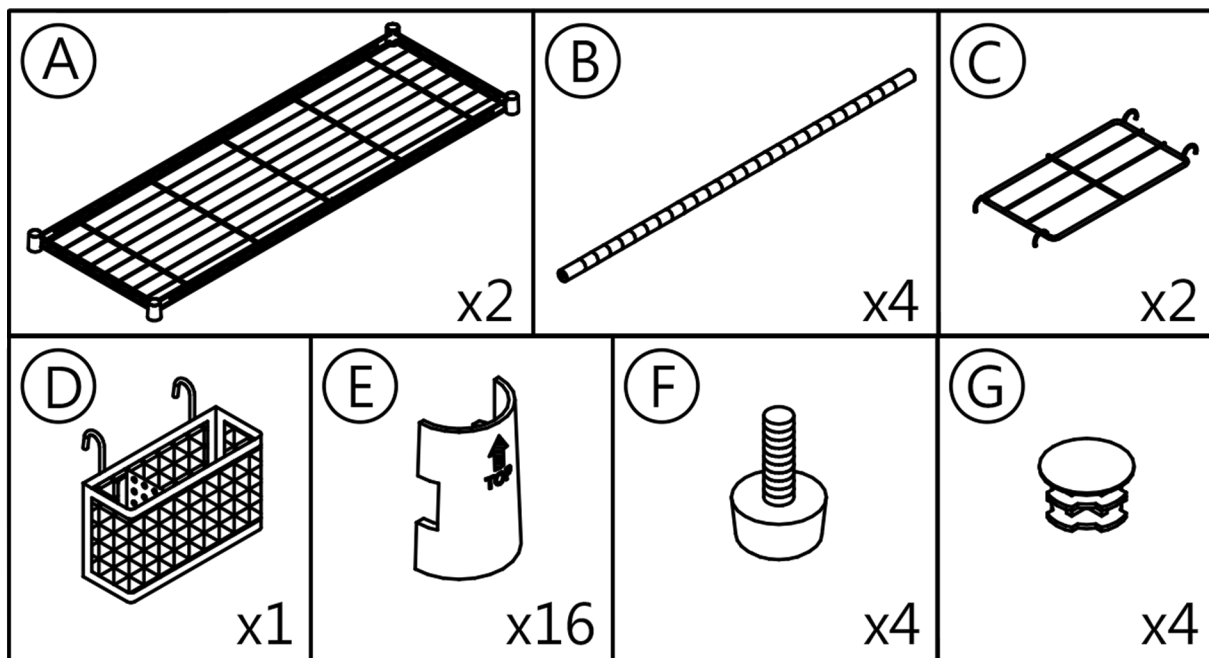

Weight Capacity: 33lbs (15kg) per shelf

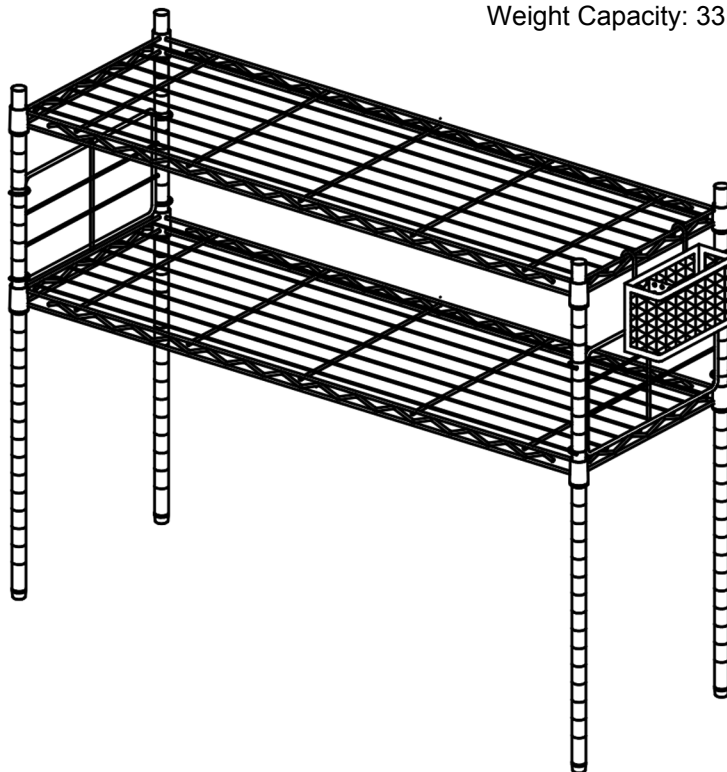

PLEASE NOTE:

We will accept missing parts request with proof of purchase only, within 30 days of purchase.
All return merchandise must be returned directly to the store and not the manufacturer with the proof of purchase.

A

1. The 2-piece plastic Sleeves have ridges that fit into the grooves. Choose the desired height of the bottom Shelf and snap a pair of Sleeves onto the Post at the desired height.
2. The beveled end of the Sleeve should be at the top.
3. Repeat for each Post

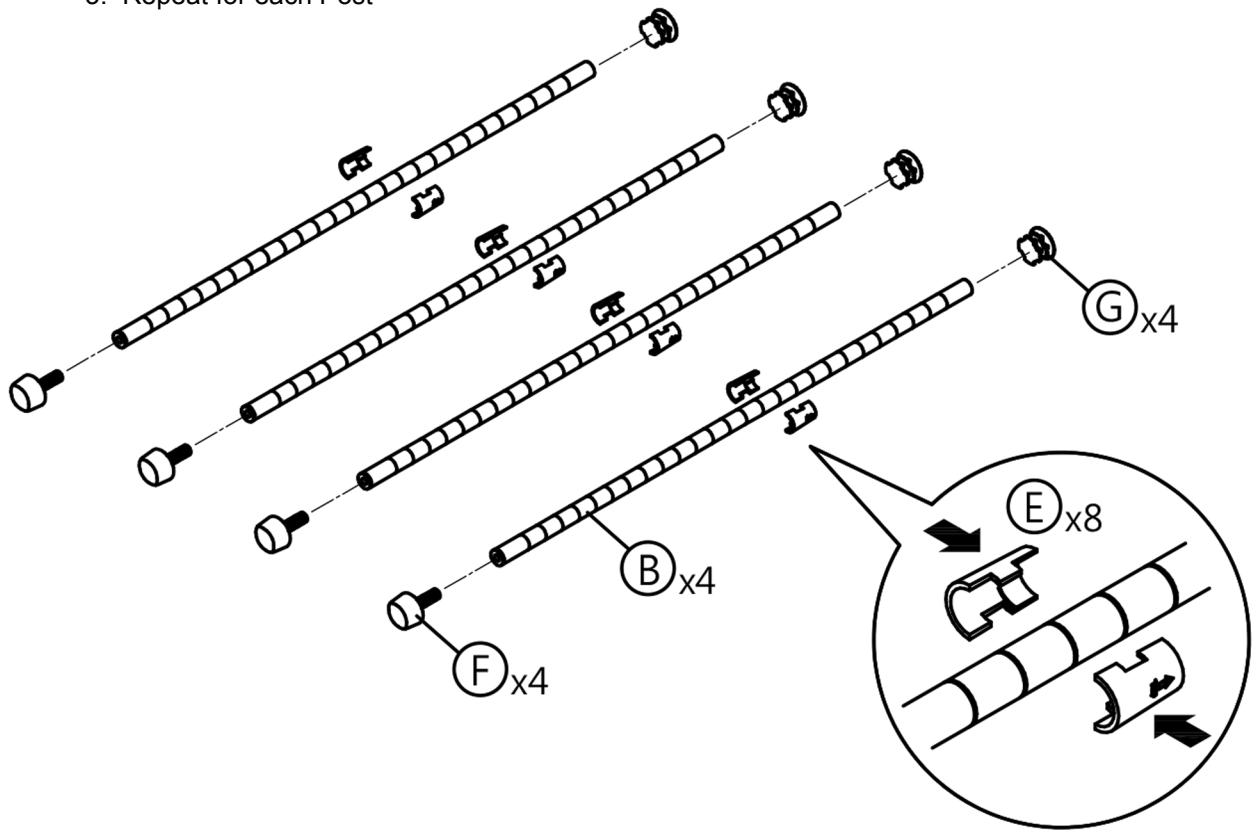
**B**

Slide one Shelf over the Posts until the Shelf sits securely over the Sleeves

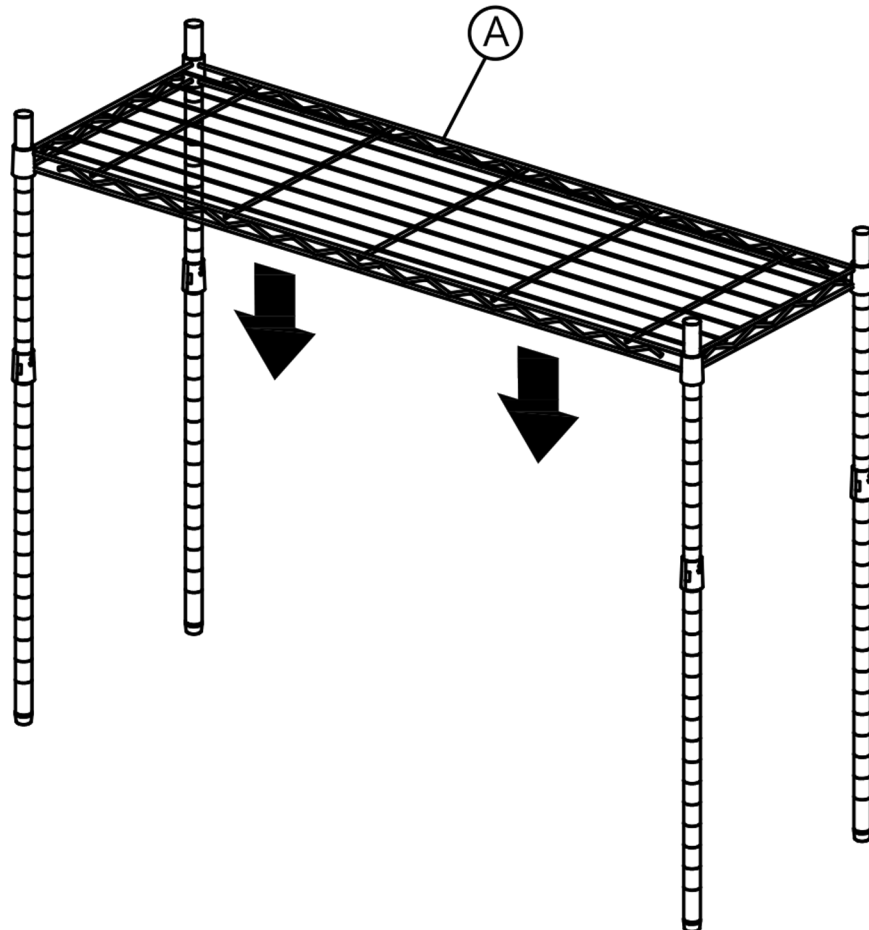

C

Repeat the Top shelf at desired height

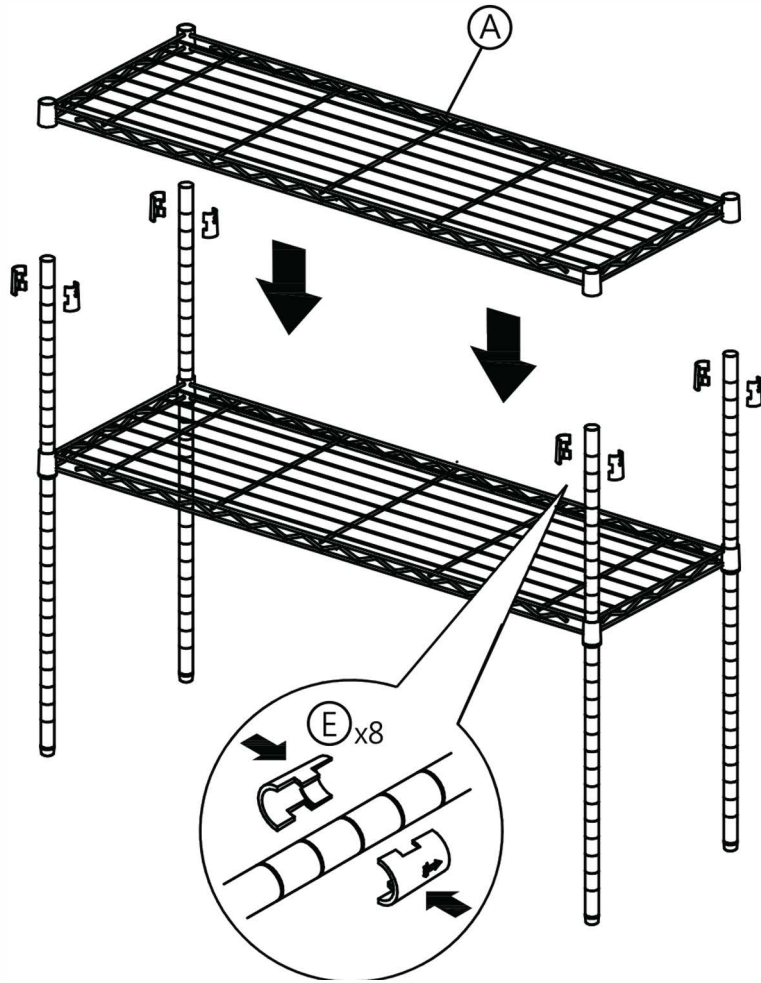

D

Snap the Wire fit into the grooves of Posts

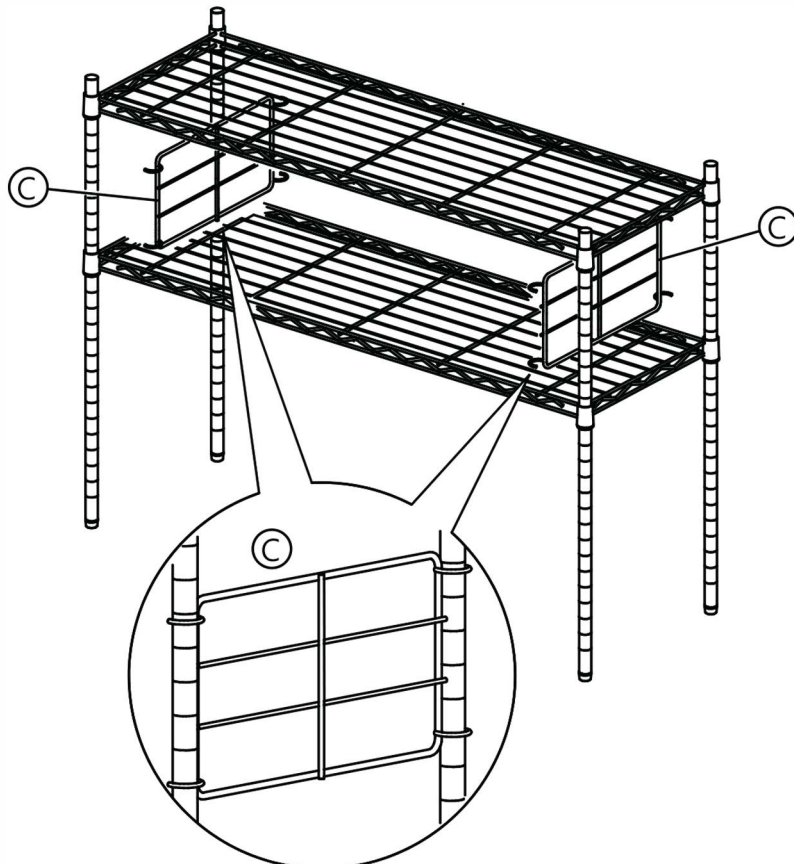

E

Attached the basket at the desired location

