







ORGANIZE IT ALL®

**PLEASE READ INSTRUCTIONS COMPLETELY BEFORE ASSEMBLY**

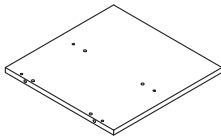
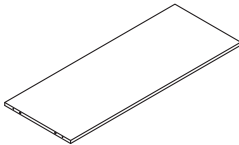
For assistance or missing parts in the USA, please email **customerservice@kennedy-intl.com** or call **Monday thru Friday (732) 654-2770**. All international (outside USA) customers who have missing, defective or damaged parts must contact the retailer directly to make an exchange or return for refund. All other customer service product and/or questions may be directed to us (in English).

**Style: NH-10802-WHT**

#	①	②	
Parts			
QTY	2	2	
#	Ⓐ	Ⓑ	Ⓒ
Parts			
QTY	8	12	12

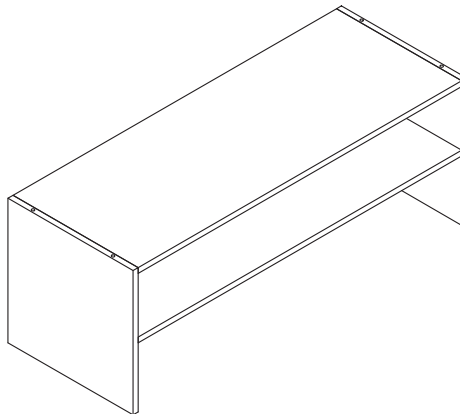

**PLEASE NOTE:**

We will accept missing parts request with proof of purchase only, within 30 days of purchase. All return merchandise must be returned directly to the store and not the manufacturer with the proof of purchase.

## Step 1

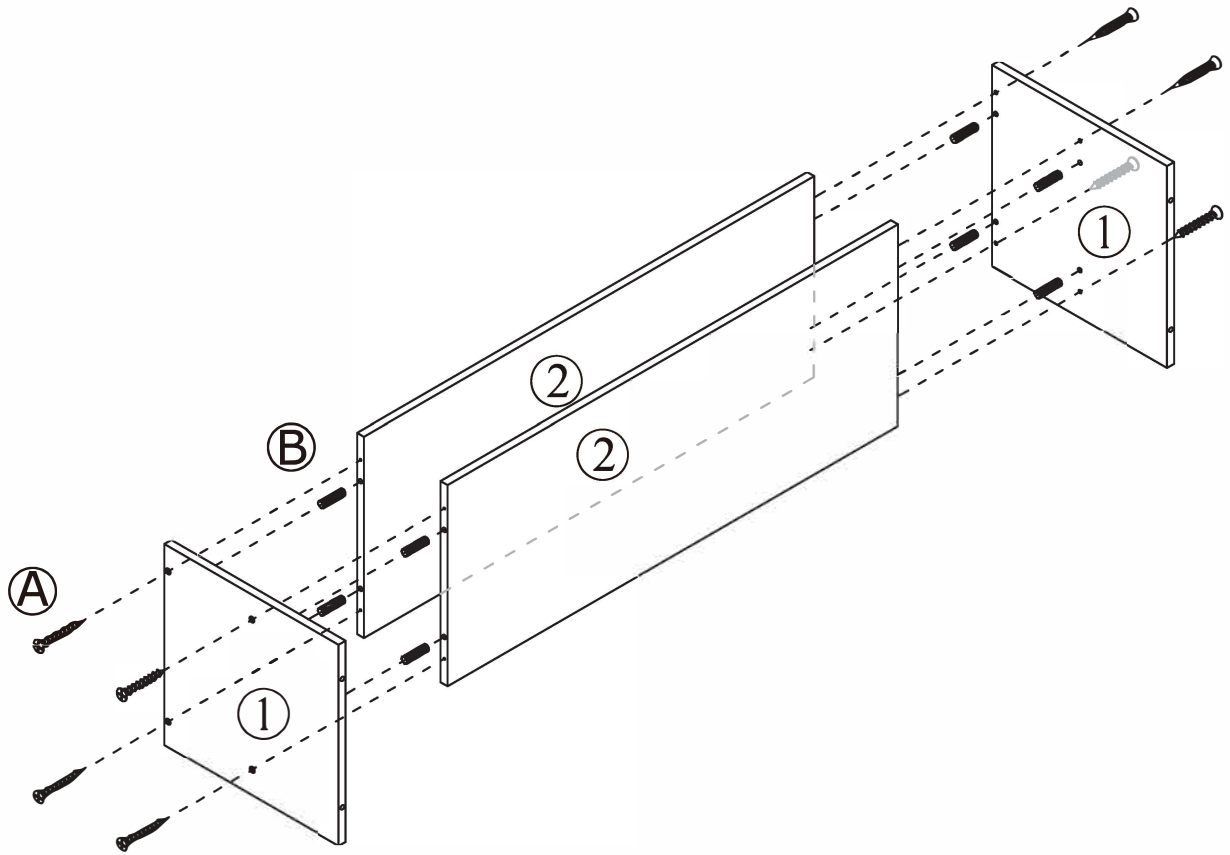

## Step 2

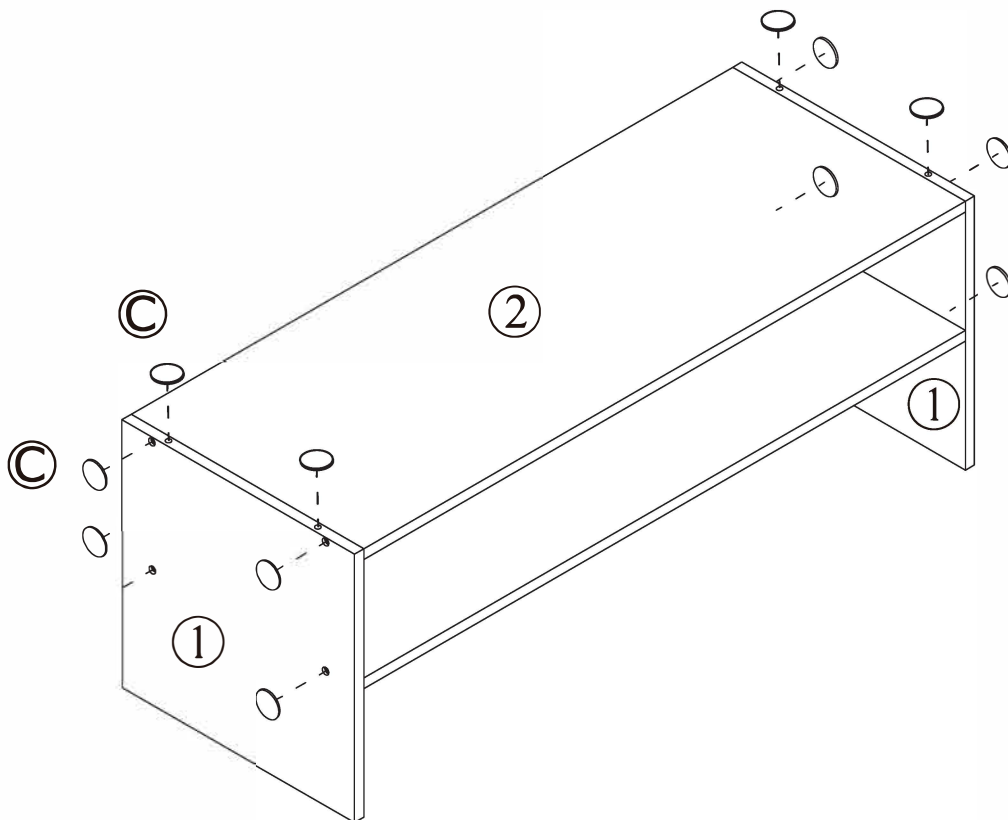

## OPTION : STACKING TWO UNITS

Stackability function illustrated on the below requires the purchase of two or more units.

Follow steps above when stacking two units.

1. Remove stickers (part #C) from the unit.
2. Assemble wood dowls connectors (part #B)
3. Connect two units together

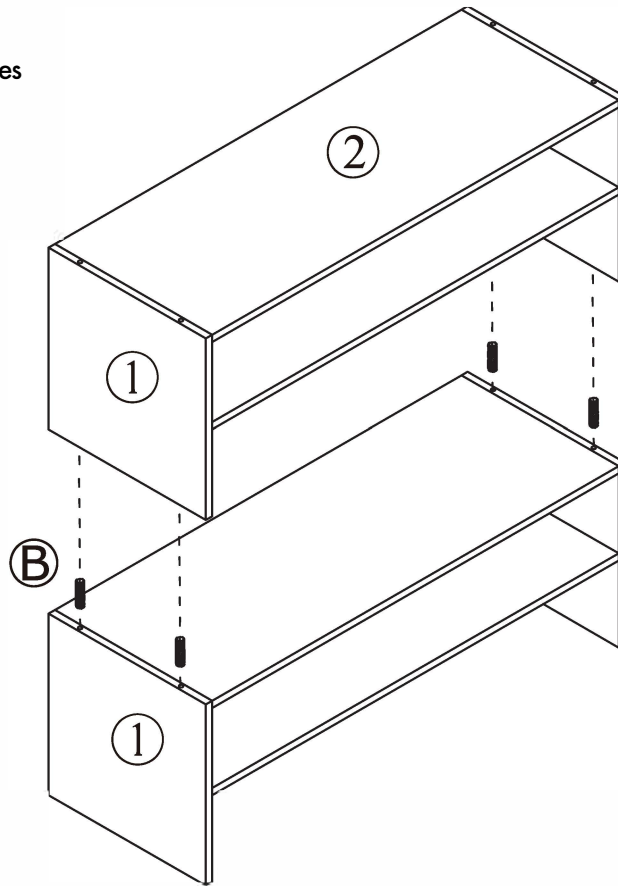

1. Covered by sticker (Part #C)
2. Complete the stacking two units

