



ORGANIZE IT ALL.™

PLEASE READ INSTRUCTIONS COMPLETELY BEFORE ASSEMBLY

For assistance or missing parts in the USA, please email **customerservice@kennedy-intl.com** or call **Monday thru Friday (732) 654-2770**. All international (outside USA) customers who have missing, defective or damaged parts must contact the retailer directly to make an exchange or return for refund. All other customer service product and/or questions may be directed to us (in English).

Style: NH-63313W1P

#	①	②	③	④	⑤	⑥	⑦	⑧	⑨	⑩
PARTS										
QTY	2	3	4	4	4	8	12	8	2	2

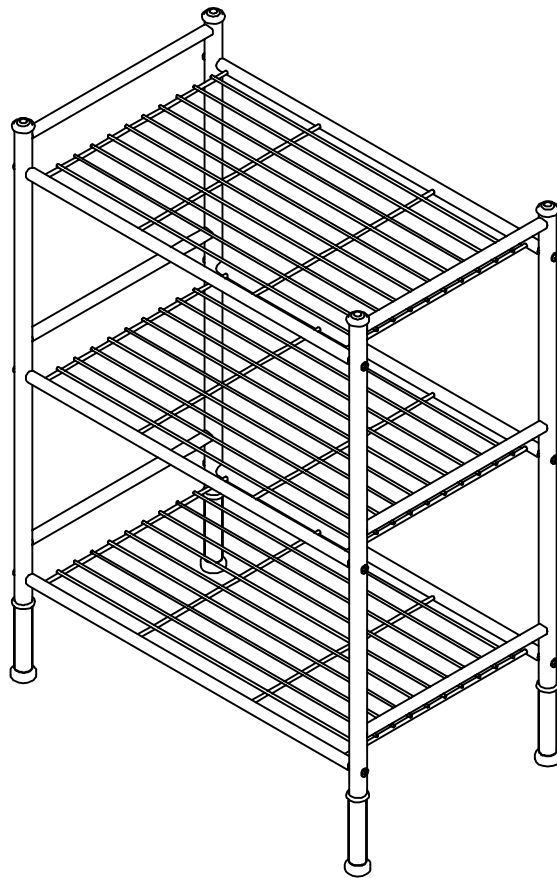

PLEASE NOTE:

We will accept missing parts request with proof of purchase only, within 30 days of purchase. All return merchandise must be returned directly to the store and not the manufacturer with the proof of purchase.

A

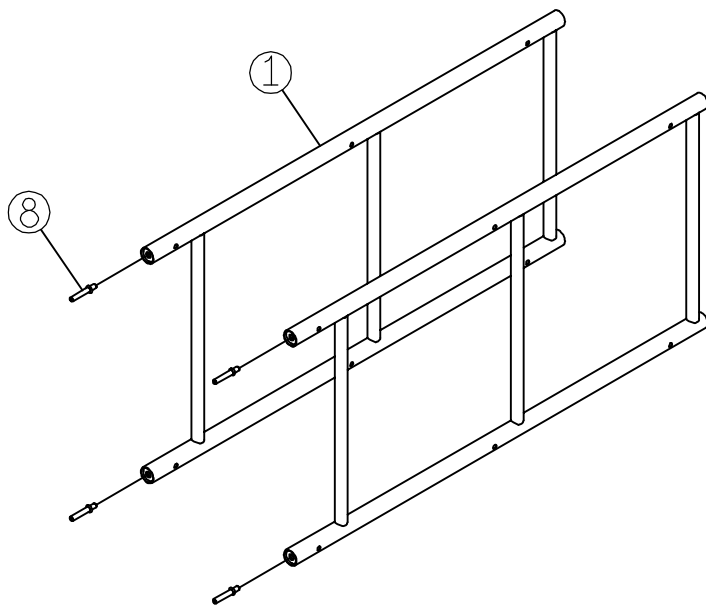

B

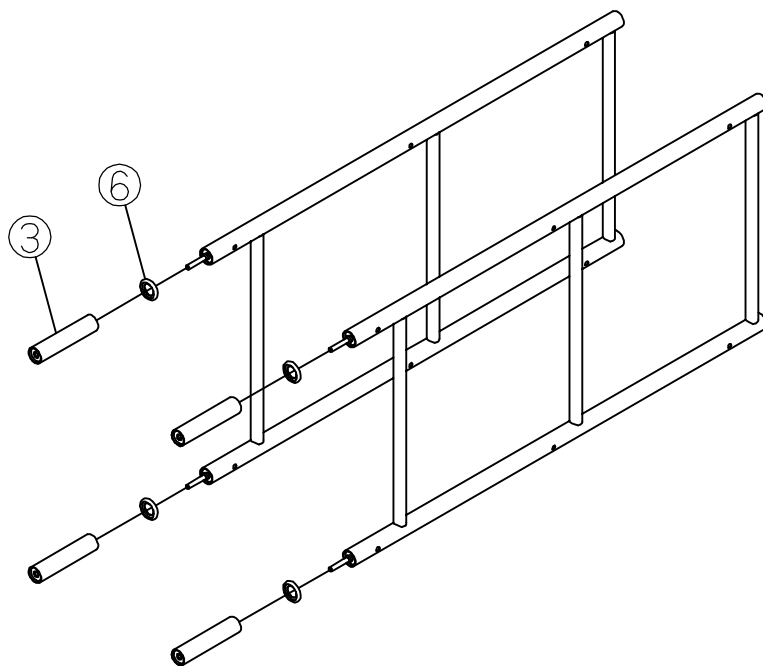

C

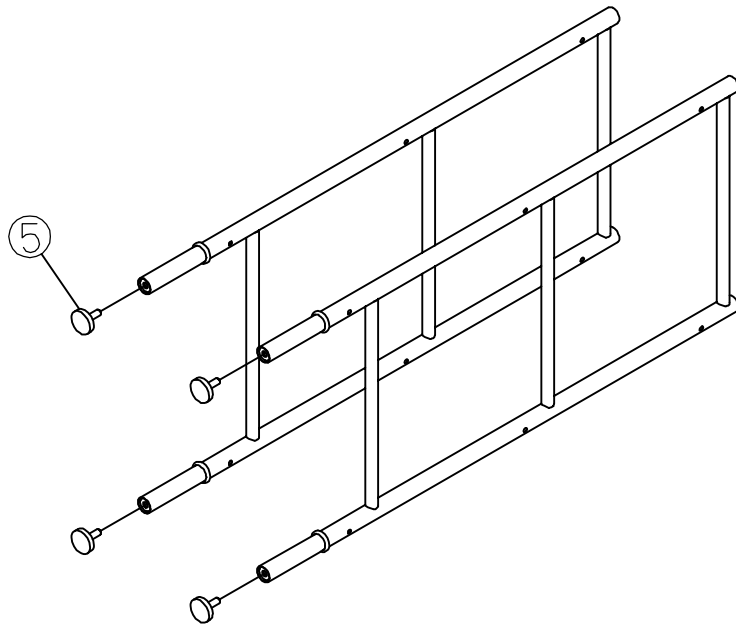

D

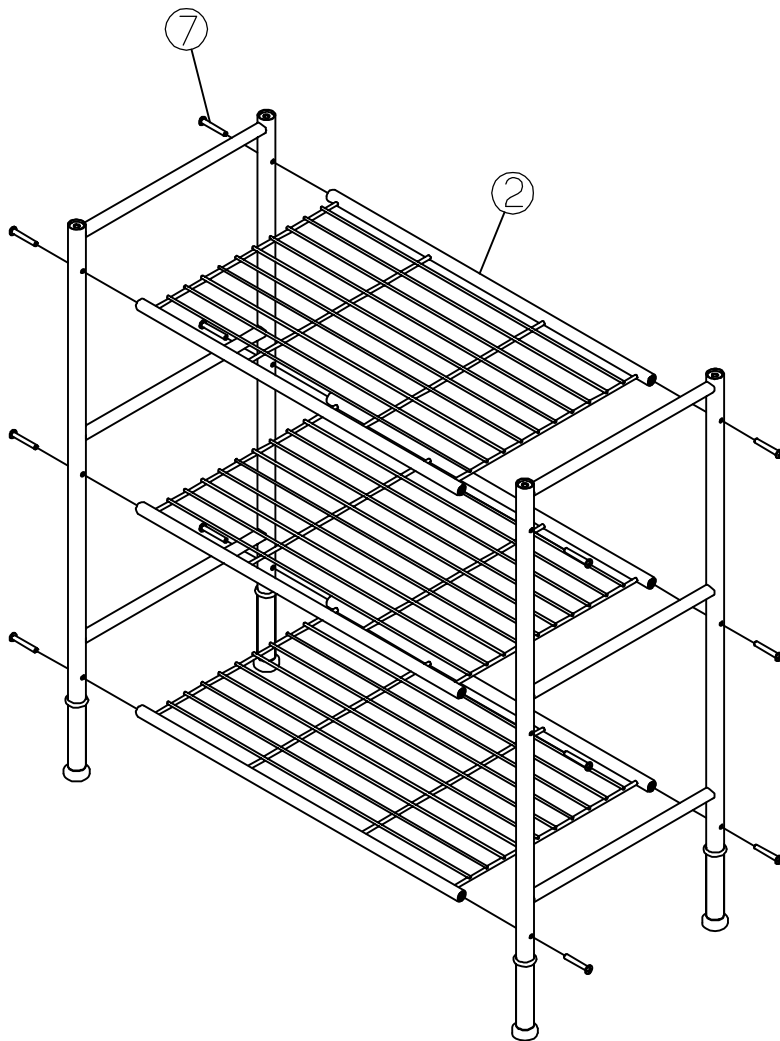

E

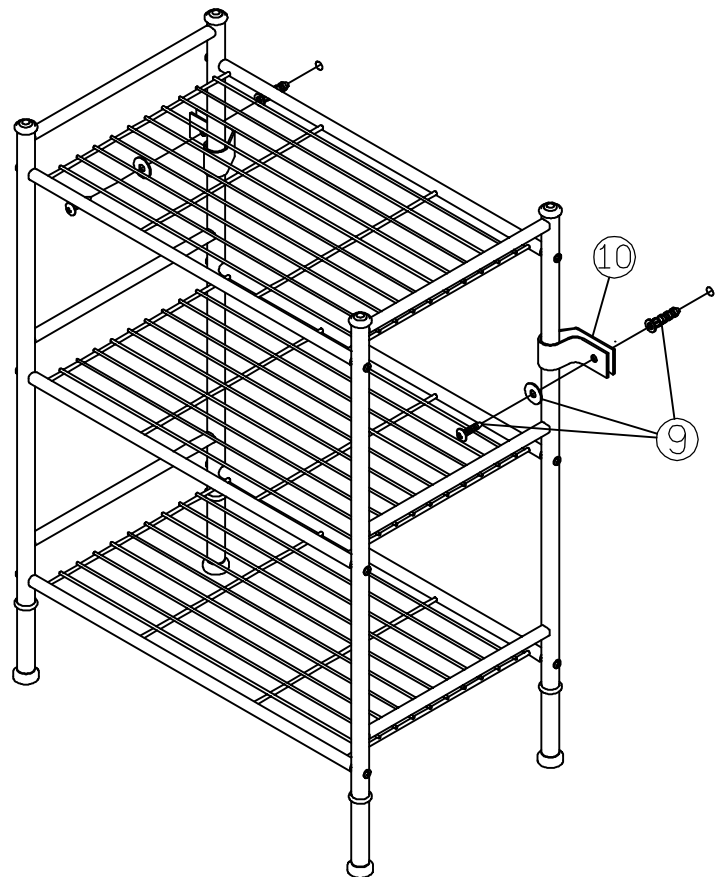
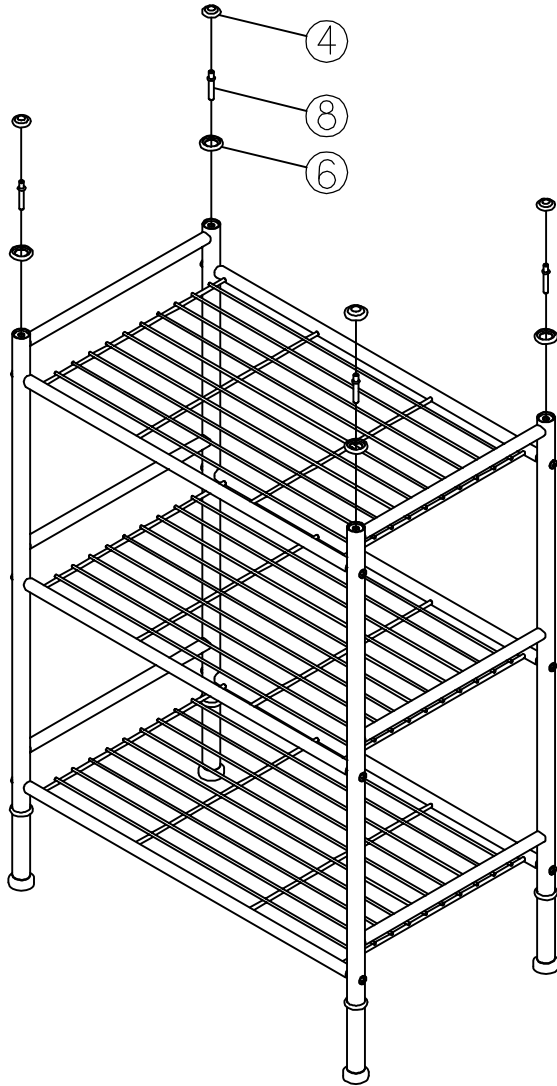

⚠ WARNING

Serious or fatal crushing injuries can occur from furniture tip-over. To help prevent tip-over:

- Place heaviest items in the lowest shelves/ Drawers.
 - Unless specifically designed to accommodate, do not set TVs or other heavy objects on top of this product.
 - Never allow children to climb or hang on shelves, doors, drawers.
 - Never open more than one drawer at a time.
- (OR)
- Do not defeat or remove the shelves/ Drawer interlock system.

Use of tip-over restraints may only reduce, but not eliminate, the risk of tip-over.